

## October 2010 CT 26 & CT 36 Dust Extractors - Overview

**FESTOOL**  
Faster. Easier. Smarter.



### **CT 26 Dust Extractor w/ HEPA**

Price: \$550.00

Item #583492

### **CT 36 Dust Extractor w/ HEPA**

Price: \$600.00

Item #583493

**Available: October 1<sup>st</sup>**

The brand new CT 26 and CT 36 Dust Extractors from Festool represent the most evolved, most complete dust removal system available today. Backed up by tools that are engineered for efficient dust removal as a top priority, and the broadest range of cleaning sets, filters, bags, hoses, nozzles, brushes available, we are confident that you will not find a more complete solution.

The new units offer many of the features that have made the CT 22 & 33 the standard-bearers for dust extraction, including HEPA filters as standard equipment, tool-actuated startup, antistatic capability, and more.

In addition, the new CT units offer greater capacity, all-new Self-Cleaning Filter Bags, and a Hose Garage as standard equipment.



# October 2010 New Products

## CT 26 & CT 36 - Key Features

**FESTOOL**

Faster. Easier. Smarter.

### Anti-static design

Anti-static hose and vacuum design minimizes shocks, clinging dust and clogging



### Sys-dock

Store and transport Systainers with the integrated Sys-Dock



### Integrated hose garage

Protect the hose and cord for easy transport or storage



### Tool-triggered activation

Auto and manual modes for tool activated or manual use. Variable suction force matches the task at hand



### Tool-less filter change

Single element design with cam-locking secures filter for efficient filtration



### Quick release bag change

Fast and easy bag changes with quick release clip system



### Self-cleaning filter bag

Made of special fleece material, the bag inflates and deflates with the cycling of the unit for maximum suction force and efficiency

### Single-point foot brake

Prevents unintentional rolling, making the unit particularly useful for use on uneven surfaces or transport



### Low abrasion tires

Protect surfaces, minimize wear, and run quieter and smoother.



## October 2010 New Products CT 26 & CT 36 - Key Features

**FESTOOL**

Faster. Easier. Smarter.



### Self-Cleaning Filter Bag

- Filter bag decompresses upon shutoff, breaking up internal dust cake to ensuring full suction until the bag is completely full
- Durable, fleece-like filter bag prevents rips or tears, keeping dust fully contained and off your floor
- Integrated closure ensures that dust stays put for clean disposal



### Integrated Höse Garage

- Protects your hose and cord during transport and storage
- Integrated Sys-Dock enables secure stacking and locking of Systainers for transport and storage
- Center handle placement for easy transport



### Increased Capacity

- A capacity increase of nearly 18% over previous models, meaning fewer bag changes and less downtime
- Fewer bag changes saves money on bag replacement costs
- Offered in two convenient sizes for the jobsite or the shop
  - CT 26 = 26 liters, or 6.9 gallons
  - CT 36 = 36 liters, or 9.5 gallons

## October 2010 New Products CT 26 & CT 36 - Accessories

**FESTOOL**

Faster. Easier. Smarter.



### Self-Cleaning Filter Bags in Action

All-new, Self-Cleaning Filter Bags eliminate dust cake, allowing CT Dust Extractors to maintain suction even when nearly full

#### Cycle ON

- Bag fills with air and inflates to fit internal profile of the CT
- Fine dust particles may form a "cake" on the inside of bag

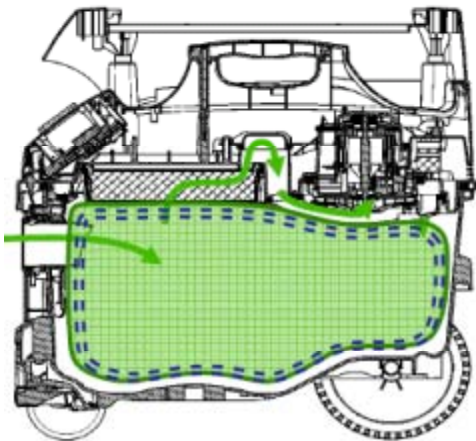

#### Cycle OFF

- Bag deflates, or decompresses, causing filter cake to break up

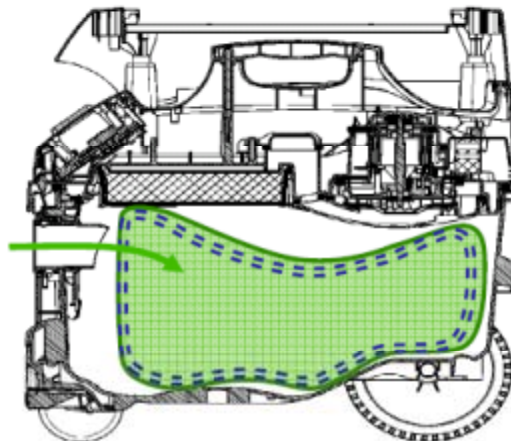

#### Cycle ON

- Bag abruptly fills again and makes contact with internal profile of the container
- Dust cake is shaken off

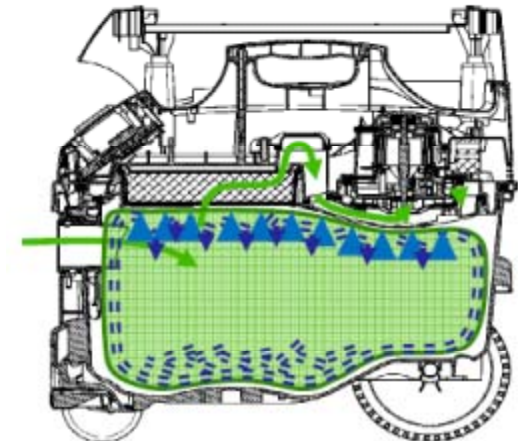

# October 2010 New Products CT 26 & CT 36 - Specifications

**FESTOOL**

Faster. Easier. Smarter.

## CT Dust Extractor Comparison – Old vs. New



	<b>CT 22 E</b>	<b>CT 26 E</b>	<b>CT 33 E</b>	<b>CT 36 E</b>
Item #	583366	583492	583368	583493
Capacity – container/filter bag	5.8/5.3 gallons (22 l/20 l)	6.9/6.3 gallons (26 l/24 l)	8.7/7.9 gallons (33 l/30 l)	9.5/8.9 gallons (36 l/34 l)
Dimensions (L x W x H)	24" x 15" x 17" (625 x 380 x 440 mm)	24.8" x 14.4" x 21.25" (630 x 365 x 540 mm)	24" x 15" x 22" (625 x 380 x 550 mm)	24.8" x 14.4" x 23.4" (630 x 365 x 596 mm)
Weight	26.5 lbs (12 kg)	28.7 lbs (13 kg)	32 lbs (14.5 kg)	29.8 lbs (13.5 kg)
Sound Level	62 dB(A) (Low Setting) 72 dB(A) (High Setting)	62 dB(A) (Low Setting) 71 dB(A) (High Setting)	62 dB(A) (Low Setting) 72 dB(A) (High Setting)	62 dB(A) (Low Setting) 71 dB(A) (High Setting)
Static Lift	90" static water lift 23000 Pa / 240 mbar	96" static water lift 24000 Pa / 240 mbar	90" static water lift 23000 Pa / 240 mbar	96" static water lift 24000 Pa / 240 mbar
Max Suction Force	134 CFM (3800 l/min)	137 CFM (3900 l/min)	134 CFM (3800 l/min)	137 CFM (3900 l/min)
Hose Garage	Accessory	Included	Accessory	Included
Filter Bag Type	Paper	Self-Cleaning	Paper	Self-Cleaning

*Metric dimensions binding*