

BENCHCRAFTED TAIL VISE MODELS M AND C

Assembly and Installation Instructions

Copyright, Benchcrafted February 2016
www.benchcrafted.com

Contents:

Quantity Description

| | |
|---|---|
| 1 | M or C Handwheel |
| 1 | 1-1/4" acme screw (left hand thread) |
| 1 | 1 1/4" acme nut block (left hand thread) |
| 1 | Sliding plate |
| 1 | Flange |
| 1 | Large washer |
| 1 | Groove pin |
| 2 | Guide rails |
| 8 | #12 x 3" screws for guide rails |
| 2 | 5/16"-18 x 4" flange bolts with washers and lock nuts |
| 2 | 5/16"-18 x 3/4" button head cap screw |
| 2 | 1/4 x 2 pan head screw (for attaching dog block to sliding plate) |
| 1 | Dymondwood (M model) or Infused Beech (C model) knob |
| 1 | Knob shoulder bolt |
| 1 | Thick washer for mounting the knob |
| 1 | Piece suede, enough to cover end of dog strip and face of dog block |



MODEL M



MODEL C

IMPORTANT !

Read and understand these instructions completely and thoroughly before starting the installation or cutting into your bench. Confirm all template measurements with your vise before installation. Do not begin installation without the vise and all hardware in your possession.



! ATTENTION !

Make sure when printing the templates that you turn off your printer's page scaling function. Then use the 1" scale on the templates to confirm that the template is actual size.

Unpacking your vise:

Some parts, especially the rails and nut block, are heavy. Be careful as you unpack and handle them. Also be aware that although we make every effort to ease all edges, being machined parts you may encounter a sharp edge or burr. If you do, ease it with some fine abrasive paper or a fine file. Some components will have a rust preventative oil applied. You should remove this oil before installing the vise. Wipe it off with a clean paper towel, followed by a clean towel with a bit of mineral spirits. This will leave a light film of oil on the parts that will help prevent rust and keep the parts moving smoothly. Dispose of oily rags in the proper way.

Assembling the Sliding Plate and Nut

The Benchcrafted Tail Vise is non-handed. That is, you can assemble the sliding plate to the nut block for either right-handed or left-handed use. If you are unsure of which one to choose, read the FAQ section on Tail Vises at our website. Unless you have a special situation, you'll assemble the plate to the nut based on your dominant hand. If you're right-handed, assemble the vise in right-hand configuration, etc.

Tools required:

3/16" Allen wrench

The plate attaches to the nut block with two included 5/16"x 3/4" button-head cap screws. Follow the pictures below to assemble your plate and nut according to right-hand or left-hand use. If you'd like to see a video on how to assemble, click the Videos tab on the Benchcrafted website.

End-cap view (as if you were standing at the Tail Vise end of the bench and looking down) :



Left-hand

Right-hand

Opposite end view (as if you were standing at the far opposite end of the bench and looking down towards the Tail Vise end)



Left-hand

Right-hand

Assembling the Handwheel and Screw

The Benchcrafted Tail Vise ships unassembled. You will need to install three parts onto the acme screw's shaft: the washer, flange, and handwheel. It only takes about a minute.

Tools required: Small hammer, and pin punch or large nail set

1. Get the handwheel, flange, large washer, acme screw and groove pin.
2. First, place a couple drops of light machine oil on the shaft end of the acme screw near the shoulder for lubrication, then slide the washer onto the shaft.
3. Next, slide the flange onto the shaft.

IMPORTANT : Face the side with the two countersunk holes away from the screw. The countersinks need to face OUT once the vise is mounted in the bench..

4. Slide the handwheel onto the shaft with a twisting motion, lining up the cross hole in the handwheel's hub with the cross hole in the shaft. Look down into the hole and position the handwheel until the two holes line up precisely.
5. Get the groove pin, punch and hammer. Examine the groove pin. One end is smoothly round, with no grooves. The other end has a short groove pressed into the steel.



6. Insert the SMOOTH END WITH NO GROOVE into the cross hole in the handwheel's hub until you feel the pin engage the hole in the screw's shaft. The pin won't insert all the way, but will stop when you reach the groove in the pin's end. Now take the pin punch and place it on the head of the pin and finish driving the pin through the shaft and the opposite side of the hub. Use light taps. The fit is machined precisely, it doesn't take much force. Do not over drive the pin, stop when its centered in the hub's diameter. The flange should spin freely on the shaft and have a little bit of play in the fit. The pin itself may fit loosely, and in rare cases slip entirely through the hub. To tighten it up, put the pin in a vise about half way, then tap the exposed end with a hammer a couple times to put a slight bend in the pin. Easy now, just a slight bend. Reassemble the vise. You're now ready to begin installation.

Getting Started

The vise can be readily adapted to thicker or thinner benches. Instructions will assume you are installing this vise in the construction of a new bench with a 4" thick top. Templates at the end of these instructions show how to adapt the vise for thinner benches. If you are installing in a left-handed position, we provide step photos of left-handed installation within these instructions . Unless noted, pics and illustrations are for right-hand installation.

IMPORTANT NOTE: The templates are sized for a 4" thick top. It's important to register the templates from the top surface of the bench if your bench is not 4" thick. This ensures the handwheel's rim will remain below the top plane of the bench.

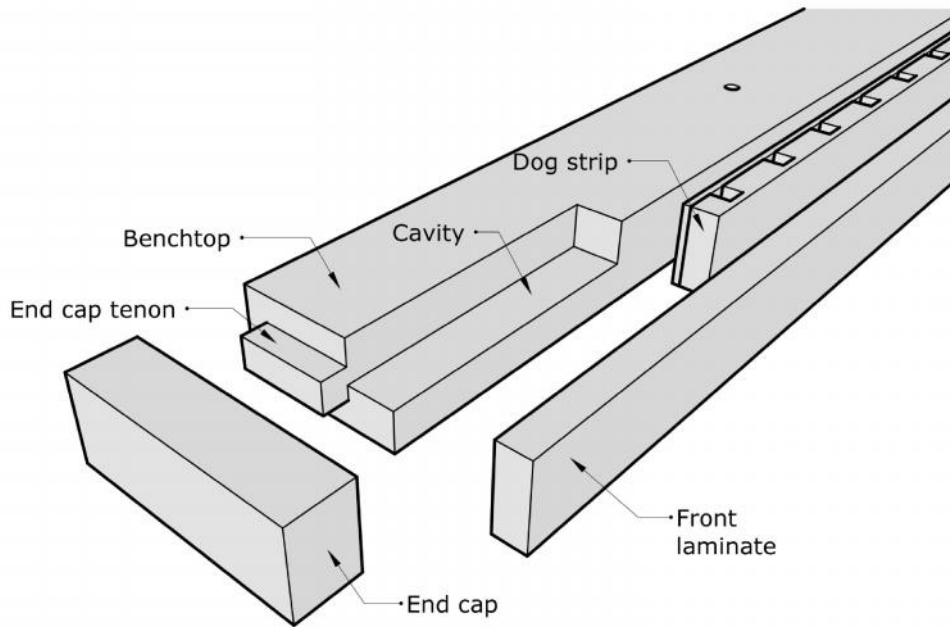

The installation is not complex. Basically all you need to do is remove enough material (what we call the cavity) from the benchtop to allow enough space for the screw and sliding plate assembly. That's it. The rest of the install is simply attaching the steel rails to the underside of the bench, and bolting the flange to the end cap. Read through these instructions completely before performing any of the steps.

The first step in installing the vise is to prepare the top of the bench. If you're building from scratch you'll have four components. The benchtop, dog hole strip (made up of two pieces if you're using square dogs) front laminate and end cap. If you're retrofitting to an existing bench, at minimum you'll only need to add an end cap. You may also want to add a dog hole strip and front laminate to make the install more precise (this will make the bench wider, obviously, so take that into consideration) Otherwise, you'll have to excavate the slot and cavity instead of building them up from the four components. The vise attaches to the bench in three places: two guide rails are screwed into the underside of the bench, and the screw/handwheel assembly (flange) bolts to the end cap. The more precisely you attach these parts, the better the vise will work. Work carefully and attentively and you'll be rewarded with a sweetly working vise.

Note: For clarity, a narrow top is used for the illustrations. This is actually the front section from our Split Top Roubo workbench.

Mill all your stock to final dimension, but leave the end cap and front laminate long. You'll join them at the corner as you install the vise.

Get ready to excavate the cavity

We recommend a 3" wide end cap. The length of the cavity measured from the inside of the end cap shouldn't be less than 13-7/8", otherwise the screw will bottom out at the end of the cavity before the flange contacts the outside of the end cap. For maximum vise capacity, the slot portion where the dog block runs can be up to 17" long. This will allow the most travel of the sliding plate assembly. Lay out the cavity and slot dimensions on your actual bench and compare them with the assembled vise (lay the screw assembly, threaded into the nut/sliding plate assembly directly on the bench) to double check the dimensions and to see how they work with your individual bench and leg locations. If your end cap is narrower than 3", take this into consideration when planning the length of your slot.

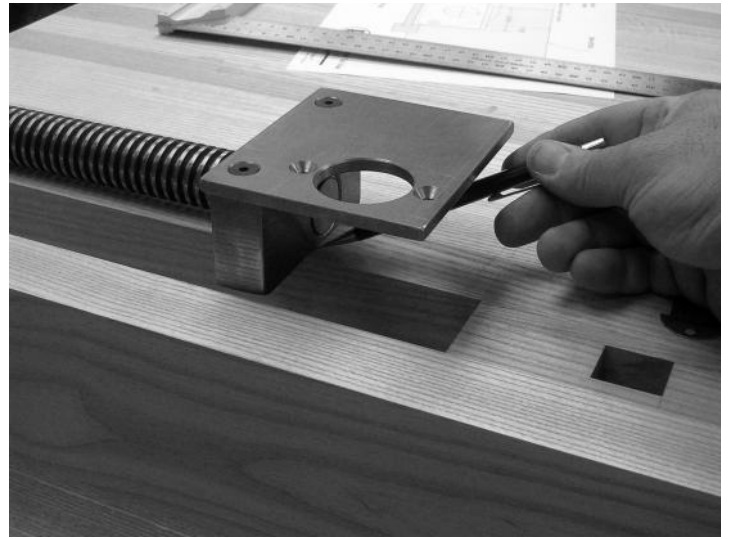
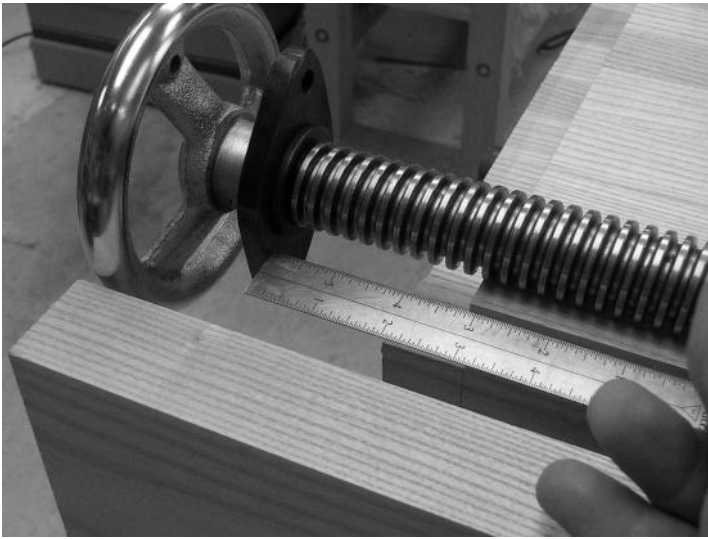

Double checking your cavity layout. Thread the nut/sliding plate assembly onto the screw fully, and position the screw assembly as if the end cap were installed (here, 2-7/8" from the shoulder, since the end cap on this bench was 2-7/8" wide)

Check the fully closed position of the vise. Your layout line for the end of the cavity should be about 1/4" past the face of the nut/end of the screw. You should also check the distance from the nut to the end of the dog strip. Make your dog block this length, plus 1" (to allow enough material to cover the top of the nut block.) Also make sure the leading face of the dog block extends at least 1/4" past the front edge of the sliding plate. See page 16 for further details. *Note: this picture shows an earlier version of the sliding plate with round dog hole.*

You should have already cut the tenon for the end cap (you can also use a robust spline, or Festool dominoes here) We use a router to excavate the cavity, but you can also drill out much of the waste, or saw kerfs with a circular saw and whack the webs out, followed by cleanup with a chisel. If you're building a laminated top, clamp the dog hole strip and front laminate in place, slipping a piece of wood the same width as the dog hole strip in the slot between front laminate and benchtop to provide support and guidance for the router base and fence.

See our video "Cutting the Cavity for the Tail Vise" on the Videos page at the Benchcrafted website.

In the picture to the right you can see the layout lines for the cavity, with the dog hole strip and long front laminate clamped in place. You can see we've taken one pass with the router in this picture.



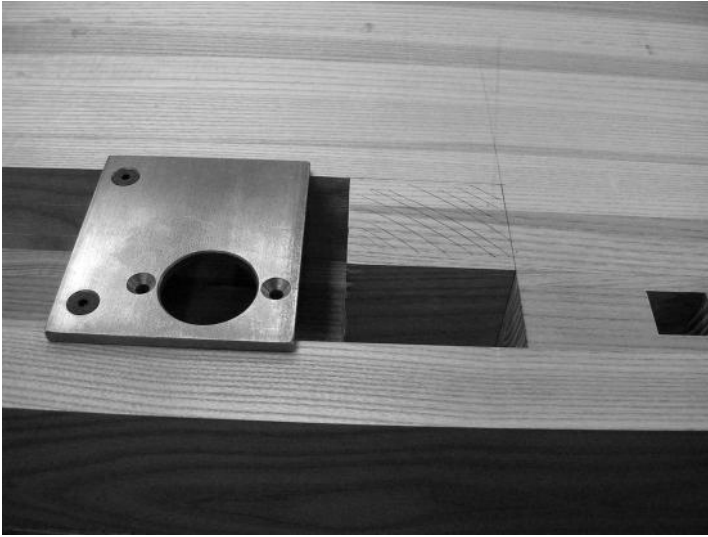

The excavated cavity. The material between the end of the cavity and the end of the dog strip (the area with the crosshatch pencil lines) may interfere with the sliding plate, depending on how deeply you mortise the guide rails. You may have to lower this area slightly to allow the plate to travel freely over this area. *Note: this picture shows an earlier version of the sliding plate with round dog hole.*



The completed cavity with dog strip and front laminate in place.



The cavity with end cap and dog hole strip in place.



Two views of a left-handed installation.

Below: front laminate removed for clarity. End cap is in place.



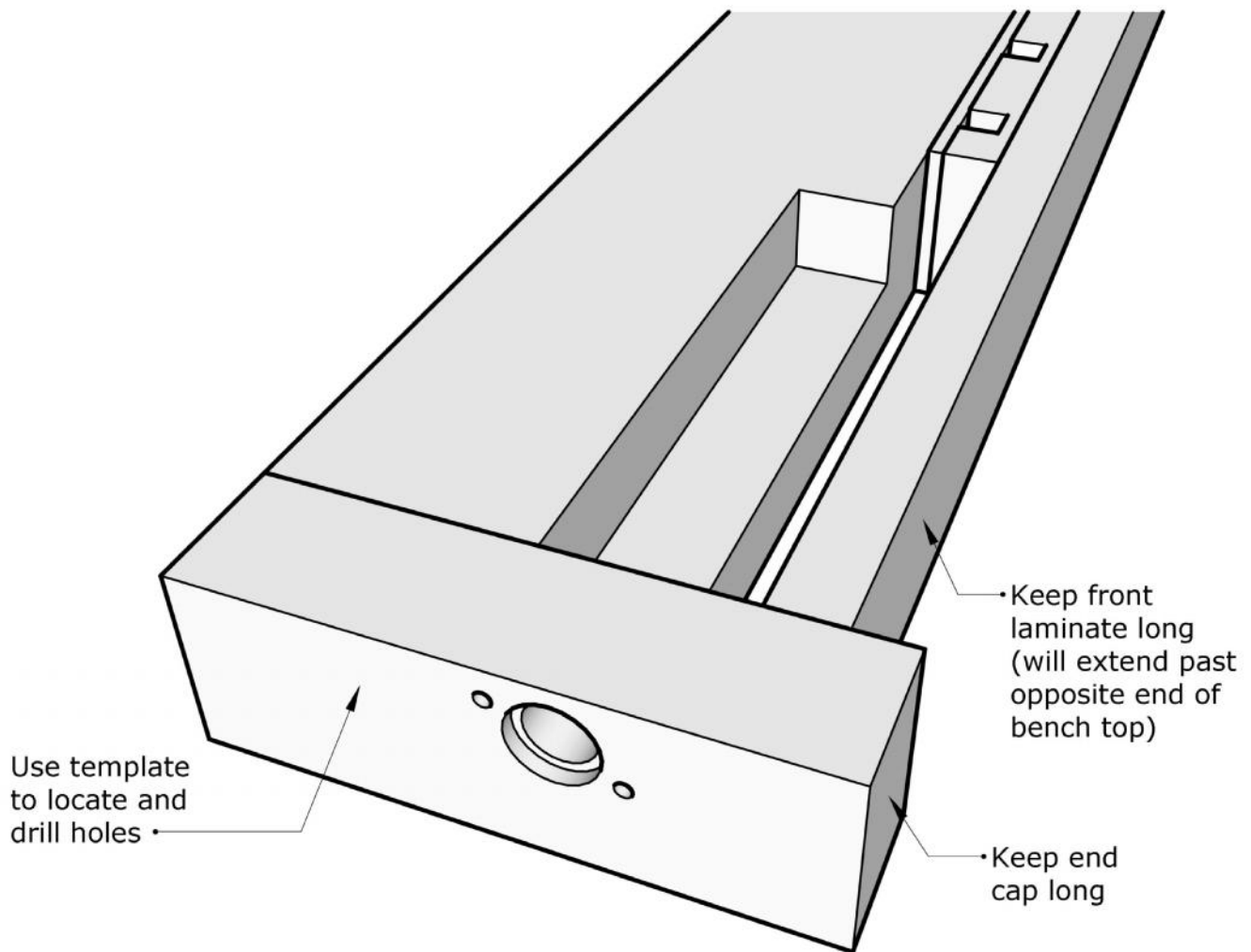

With the cavity excavated you can glue the dog hole strip on. After that, finish your end cap-to-top joinery (but don't install it permanently yet.) We like to use our End Cap Barrel Nuts. These are easy and quick to install. You can also use simple hex or square nuts in blind holes that intersect with the bolt holes. Another option is to use 1/2" Spax brand lag screws to attach the end cap. It's not as strong, but we've found it to be plenty robust. Use the sequence on page 10 to drill the end cap for lag screws. With the end cap joinery complete, you now know exactly where the end cap will be in the final assembly. Now place the template on the outside of the end cap (registered from the **top surface** of the bench) and line it up horizontally with the slot where the dog block rides. Mark with an awl through the template, remove the end cap, then drill the counterbore for the washer (behind the flange) at 1-3/4" dia, 3/16" deep, the clearance hole for the main screw at 1-1/2" dia., and the two holes for the flange attachment at 5/16" dia.

With the end cap to top joinery complete you can layout the joinery for the front laminate to end cap. With the end cap installed (but not permanently) Slide the front laminate to the inside of the end cap and make sure the slot (where the dog block runs) is parallel and consistent in width along its entire length.

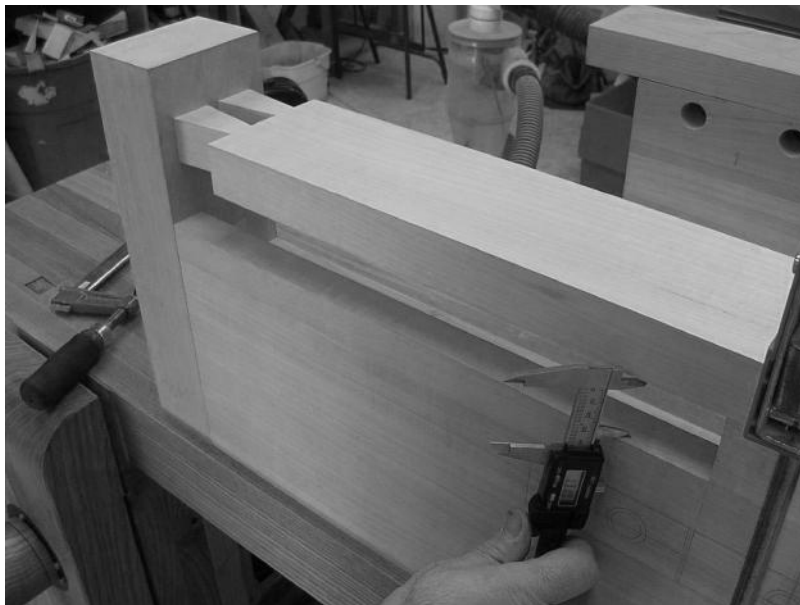

Mark the end cap length directly from the front face of the front laminate, remove the end cap, cut it to length, and reinstall it. In the picture below you can see that the dovetails have already been cut on the end of the front laminate for joining to the end cap. This is why you kept the front laminate long, to leave room for cutting joinery.

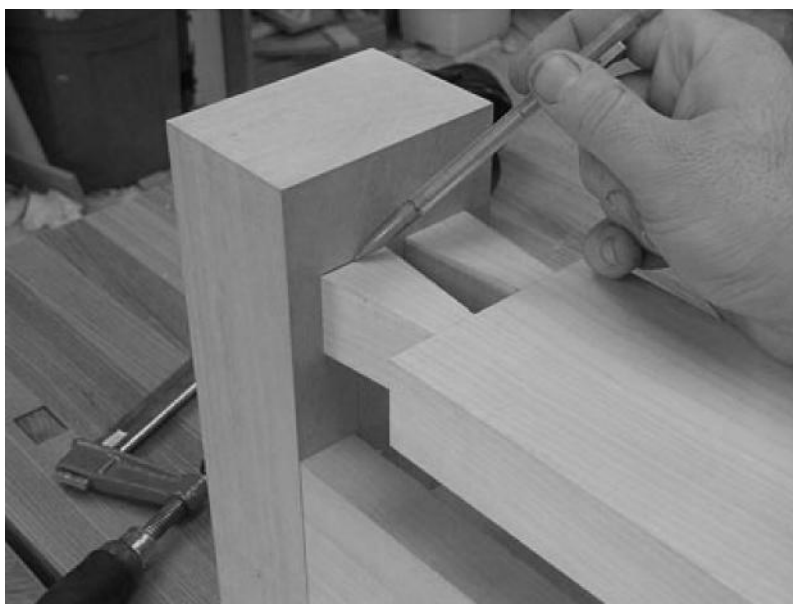

This large “condor tail” is beautiful in the finished bench, but its not a requirement. However, if you’d like to try it, we wrote a detailed article “How To Make Condor Tails” for Popular Woodworking Magazine issue #191. The article is free to read online here: <http://www.popularwoodworking.com/techniques/make-condor-tails> If for some reason you can’t access the article, contact us.

An easier method is to use massive lag screws to fasten the end cap to the front laminate and bench top. First drill the pilot holes in the end cap on a drill press using a bit that matches the root diameter of your lag screw. Fasten the end cap in place on the bench top and then clamp the front laminate firmly and accurately in place. With a powered drill use the holes in the end cap to guide your bit straight into the end of the front laminate. Drill as deep as you can. Remove the end cap and enlarge the holes in the end cap (to the size of the threads) and bore deeper into the front laminate if necessary for the lag screws. Be careful and diligent here, since these holes need to be positioned precisely. Use a sharp bit and back the drill out frequently to clear the chips. Reassemble the end cap and drive the lags into the front laminate to cut the threads. When you glue the front laminate to the dog hole strip, have your socket wrench handy so you can reinstall the lags immediately during the glue-up.

Make sure you use 1/2” Spax brand lags. They are made in American or Germany, and are the only lag screws we recommend for this technique, since they are properly heat treated, and have deep, robust and crisp threads. Do not use the hardware-store variety lags that are made in Asia. They are soft, have blunt, shallow threads and aren’t much better than using a smooth dowel. Our local big box store carries Spax, but you can get them online as well.



End cap joined with Spax lag screws



Marking the pin locations
from the tails.



The joint going together.

When you're satisfied with the fit of the end cap and front laminate (whatever joinery you've chosen) you can glue the front laminate in place, and attach the end cap permanently.

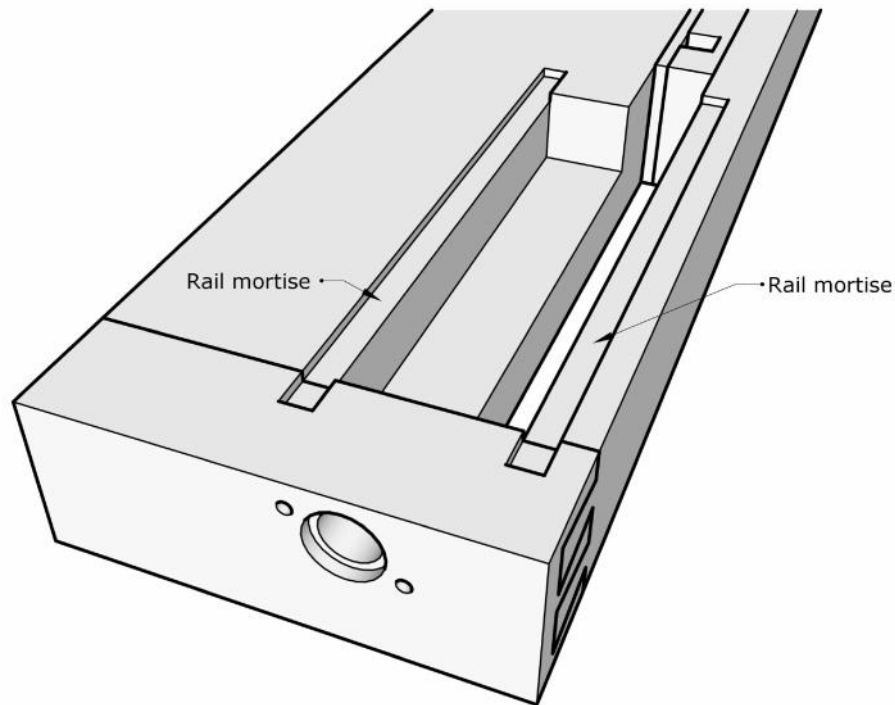

Get ready to cut the rail mortises

With the bench's top completely assembled, the next step is to cut the mortises for the two guide rails. The mortises are laid out on the underside of the top. Use the template, again registered from the top of the bench to determine the depth of the mortises. The inner edges of the rails should end up flush with the inside face of the front laminate and the inside face of the cavity. If your bench is exactly 4" thick, you can simply mortise 1/4" deep. If you mortise too deep its not a huge mistake. You can simply cut some shims for the mortises to locate the rails properly. The distance from the rails to the tapped hole in the nut block is critical. We've designed the vise for a bit of wiggle room here, but best to shoot for spot on. Again, if things are off, its easily corrected with shims. You can use paper, veneer, or even layers of the ever-handy blue painter's tape. Just make sure the rails seat flatly and in the same plane. They need to be coplanar for the sliding plate to ride the rails smoothly.

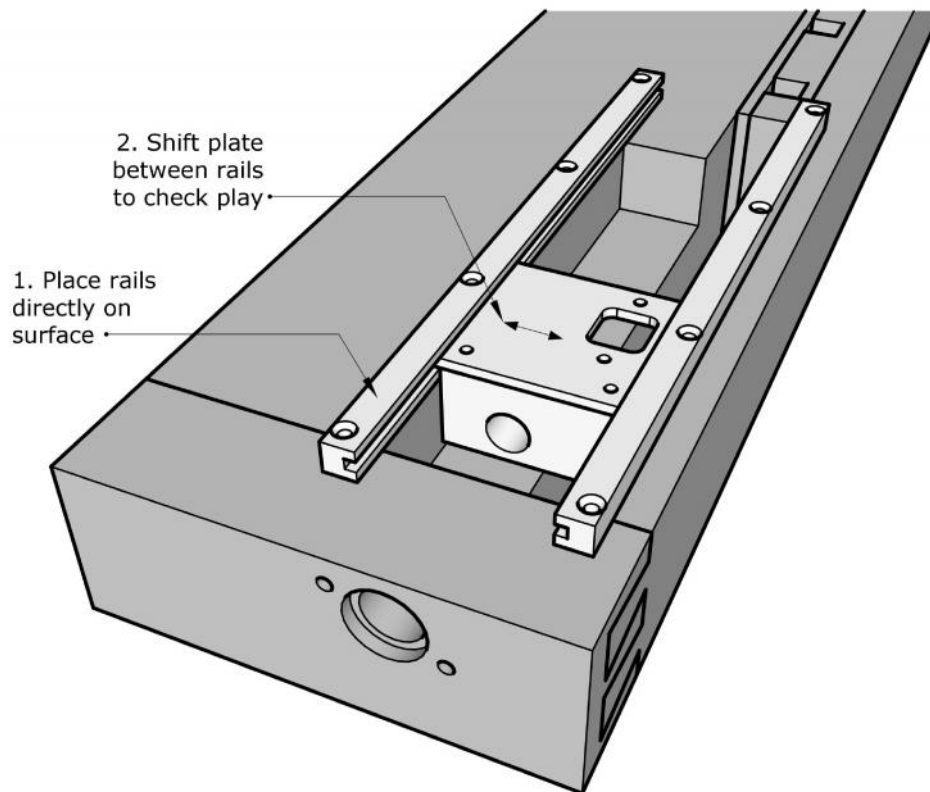

The sliding plate rides in grooves milled into the guide rails. Although the edges of the sliding plate and their mating grooves are accurately machined, it's possible to position the guide rails too close together. This could cause the sliding plate to bind in the grooves. You want a loose fit here. It's best to position the guide rails so the sliding plate has some lateral movement. 1/16" is adequate. The templates account for this, but best to double check in real time. Place the rails directly on the surface of the bench top with the sliding plate riding in the grooves, and position them so the inside edges are flush with the inside faces of the front laminate and cavity. Without moving the rails, gently shift the plate back and forth between rails to check for this play. Again, make sure the rails don't move. You can clamp them in position for this test if you wish. Slide the plate to both ends of the rails and test again.

In use, the lateral tracking of the plate is not dependant on the rails. The fit of your dog block (which you fit as the last step), along with the main screws's alignment will determine the ultimate travel of the vise, so it's important to install the rails with this side-to-side play. This also allows for some wood movement during changes in your shop environment.

It's also important that the mortises for the guide rails be parallel to each other to prevent the sliding plate from binding, parallel to the slot (to match the travel path of the dog block), and square in both planes to the end cap, so when the screw is engaged, the plate travels smoothly along the screw. There is some room for error, but it's best to shoot for perfection. This will guarantee a smooth running vise. The most important plane to consider is whether the rails are vertically parallel (coplanar). The grooves in the guide rails are milled for a smooth fit with the sliding plate, so there isn't much room for error here. Again, shims can correct almost any error.

Also, be sure the ends of the rails are not going to interfere with any joinery for attaching the top to the base, or the bench leg itself.

Once you're satisfied with the location of the rails, scribe around them with a knife or sharp pencil. Make sure you position the rails along their length so the last screw hole falls within the end cap. This really adds a lot of strength to the end cap connection.

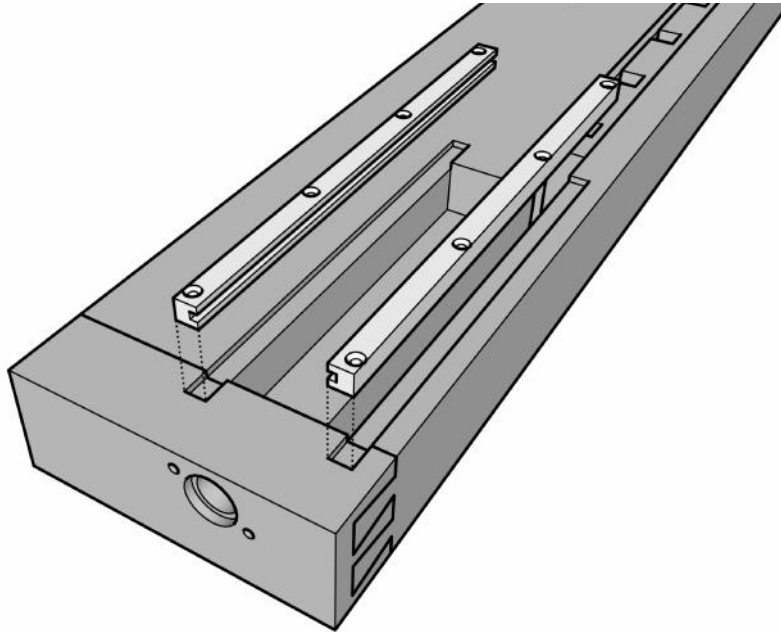

Cutting the mortises is easy work with a router, 3/4" straight bit and edge guide. Square up the ends with a chisel. If you work by hand, chisel and router plane are the tools for the job. Either way, make the floors of the mortises as dead flat as you can, so when you drive the screws through the rails, they seat completely flat. If one end of your mortise is sloping down, the screws will deform the rail. Try to make the rails fit precisely with no play. This will help keep the rails from shifting when you drill the pilot holes for the attachment screws. Once the mortises are cut, slip the rails and sliding plate assembly in place and test the sliding plate again for smooth movement and some play. Also make sure the nut block isn't touching wood in the cavity. If it is, correct this now. The sliding plate should never come in contact with the top.

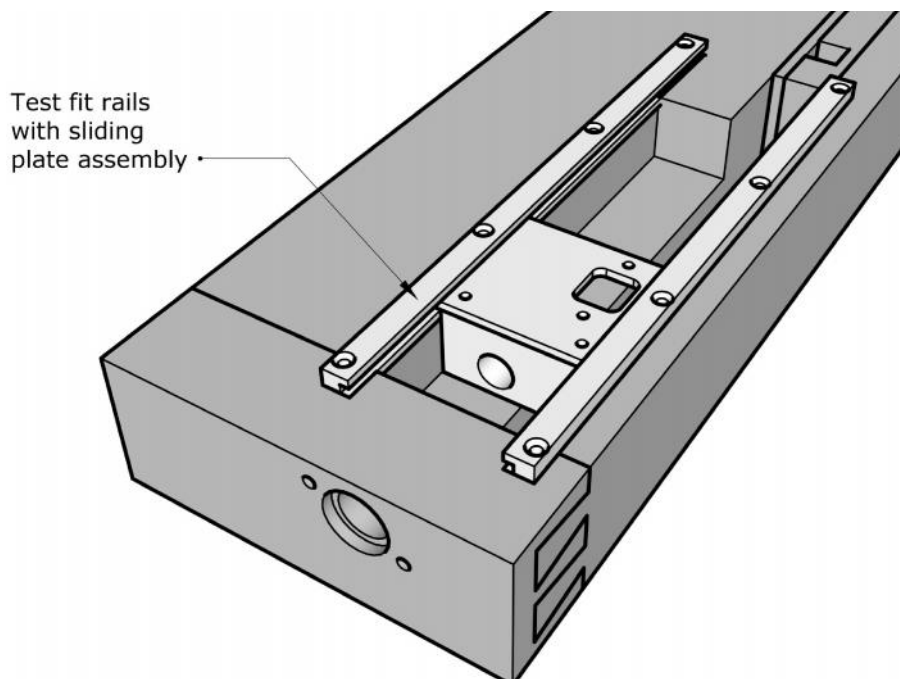

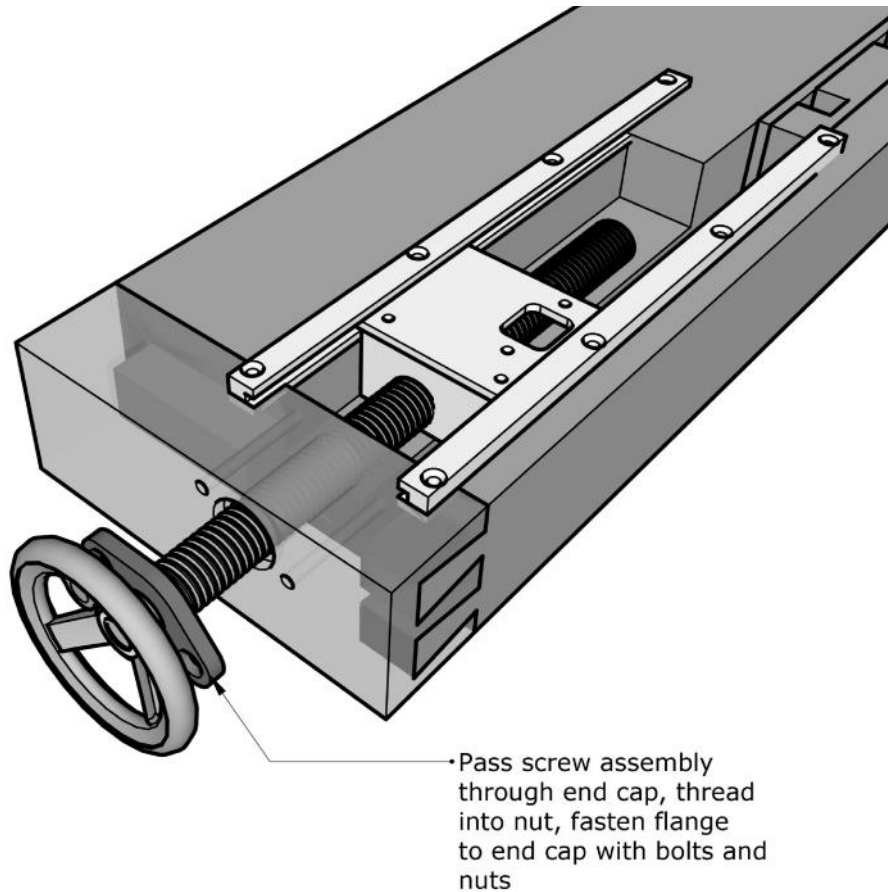

With the rails and sliding plate in place, pass the screw assembly through the end cap, thread it into the nut, and fasten the flange to the end cap, (use plain 5/16 nuts, as the nylon lock nuts should be used only for the final assembly) and test the operation of the vise. Everything should run smoothly and freely. Sight down alongside the screw, it should be parallel with the slot. If you're satisfied with the fit you can drill for the eight #12 screws that hold the rails to the top. Use a properly sized center punch (a bradpoint bit will also work) to locate the holes, directly through the rails. You may need to remove the rails to pre-drill deep enough for the 3" screws. Drill and drive the four corner screws first. Tighten one, then test the function of the vise. Repeat for the remaining three screws. If the vise binds after tightening a screw, you've located the spot where you may need to add a shim. Drill and drive the remaining screws the same way. If the vise binds up when one or two particular screws are cinched down, feel free to leave it a bit loose if it allows the vise to run freely. The vise doesn't need all eight screws completely cinched down tight to function properly. We've engineered these extra holes into the rails for just such a purpose.

Extra long flange bolts are provided to accommodate a range of end cap thicknesses, so you may want to cut off the extra thread past the nut. Don't cut them too short otherwise the nylon locking feature of the nuts will be useless. These two bolts provide the opposing force for the vise and must be fully engaged in the lock nuts.

A drop of light machine oil between the flange and the handwheel's hub (apply while turning the handwheel) helps keep the screw turning smoothly.

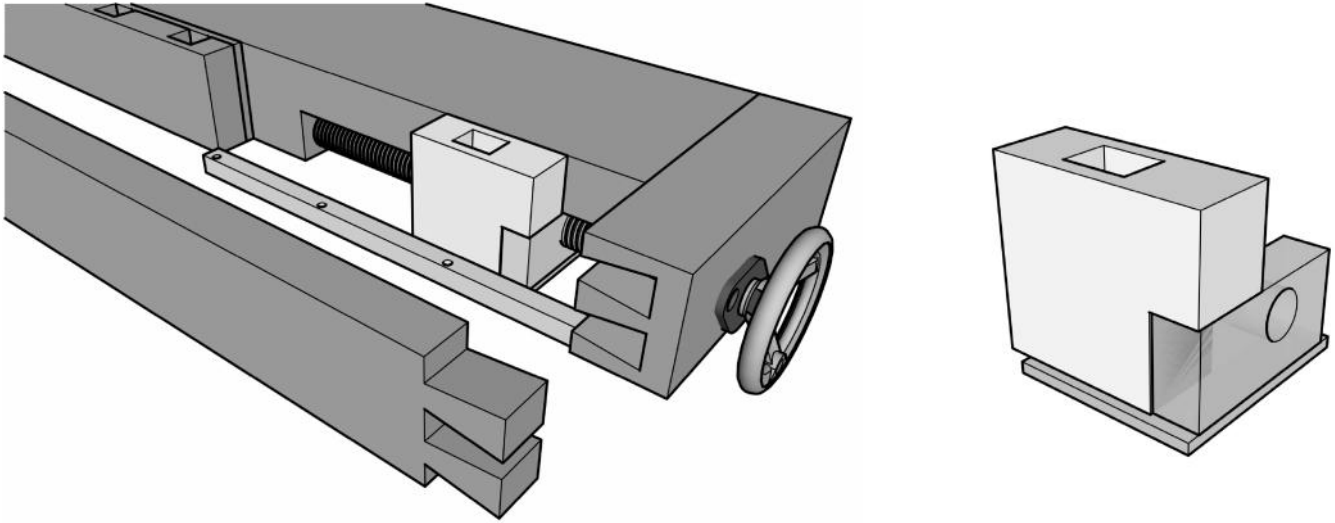

Next, make the dog block. It should fit well in the top's slot, but not tightly. It needs to slide freely. Make the block a little too tall, then plane it flush to the top after installation.

For square dog holes, the dog block is made just like the dog strip on a bench top. (The dog hole is milled into the side of the block, then the outer cap is glued on.) When you make your dog strip, make it extra long, create an extra dog hole for the dog block, then cut the dog block free before gluing your dog strip on.

Install the dog block by marking through the sliding plate with a center punch (or simply drilling directly through the plate's holes) and predrilling for the two 1/4" x 2" pan head screws. These screws are used to hold the block in place only. Clamping force is transferred directly to the dog block and dog by the vertical portion of the massive steel nut block. Make sure you drill accurately. You don't want the screws to be offset, thus forcing the dog block tight against one side of the slot causing friction. Ideally, the sides of the dog block fit loosely (but not sloppily) in the slot for smooth and effortless action. If you find one side rubbing the slot, remove the dog block and plane that side until it rides smoothly. Rubbing the dog block and slot with paraffin will also help.

The face of the dog block and the end of the dog hole strip are then lined with the included suede for a good grip when holding work in the jaws of the vise. Any glue will work, but we like to use contact adhesive for easier removal when the leather wears out.

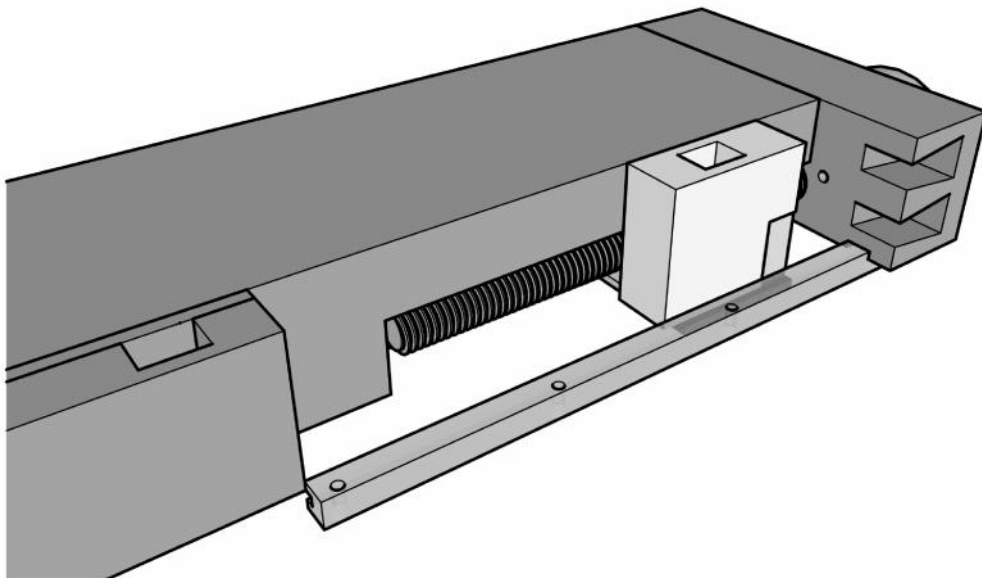

The handwheel is cast iron and may rust. Check our FAQ for info on treating the handwheels to help prevent this. If your shop is conditioned this shouldn't be a problem. The rest of the vise is lightly oiled steel and should be kept lubricated for smooth action. Like any fine tool, the vise should be periodically cleaned. It's important to keep the screw and nut free of built-up dust and grime. The precision acme screw is smooth and polished, so it should need only occasional attention. Unbolt the flange and back the screw out of the bench. Clean out the threads with compressed air or a small brush. Also clean the dust and grime from the guide rail slots. Reapply a light lubricant periodically, depending on your shop conditions.

Using the vise is simple. When clamping between dogs it's easy to overdo it. Just spin the handwheel, advancing the dog block up to your workpiece and let the dog stop against it. It's usually not necessary to tighten the vise past this point, especially with thinner pieces. We recommend lining the faces of your dogs with leather, this will dramatically increase the grip of the vise while using less clamping pressure. We offer suede scraps on our ordering page for such a purpose. You'll be impressed with the holding power of the vise. It's not necessary to crank the handwheel tightly to hold the workpiece. When clamping between jaws (as in dovetailing or other vertical sawing operations) spin the vise to the workpiece, then grasp the rim of the handwheel and give it another 1/8 or so turn. If you've lined your jaws with suede, this provides enough grip that you can even move your bench with the workpiece--much more force than any joint cutting operation would entail.

For more tips and techniques, please visit our blog which contains lots of information on using the vise. Select "Tail Vise" from the "Categories" list.

If you have any technical questions about your installation, we're glad to help. For technical questions only, write to us at ja@benchcrafted.com.

Thank you for purchasing the Benchcrafted Tail Vise. We hope you enjoy using the vise as much as we do.



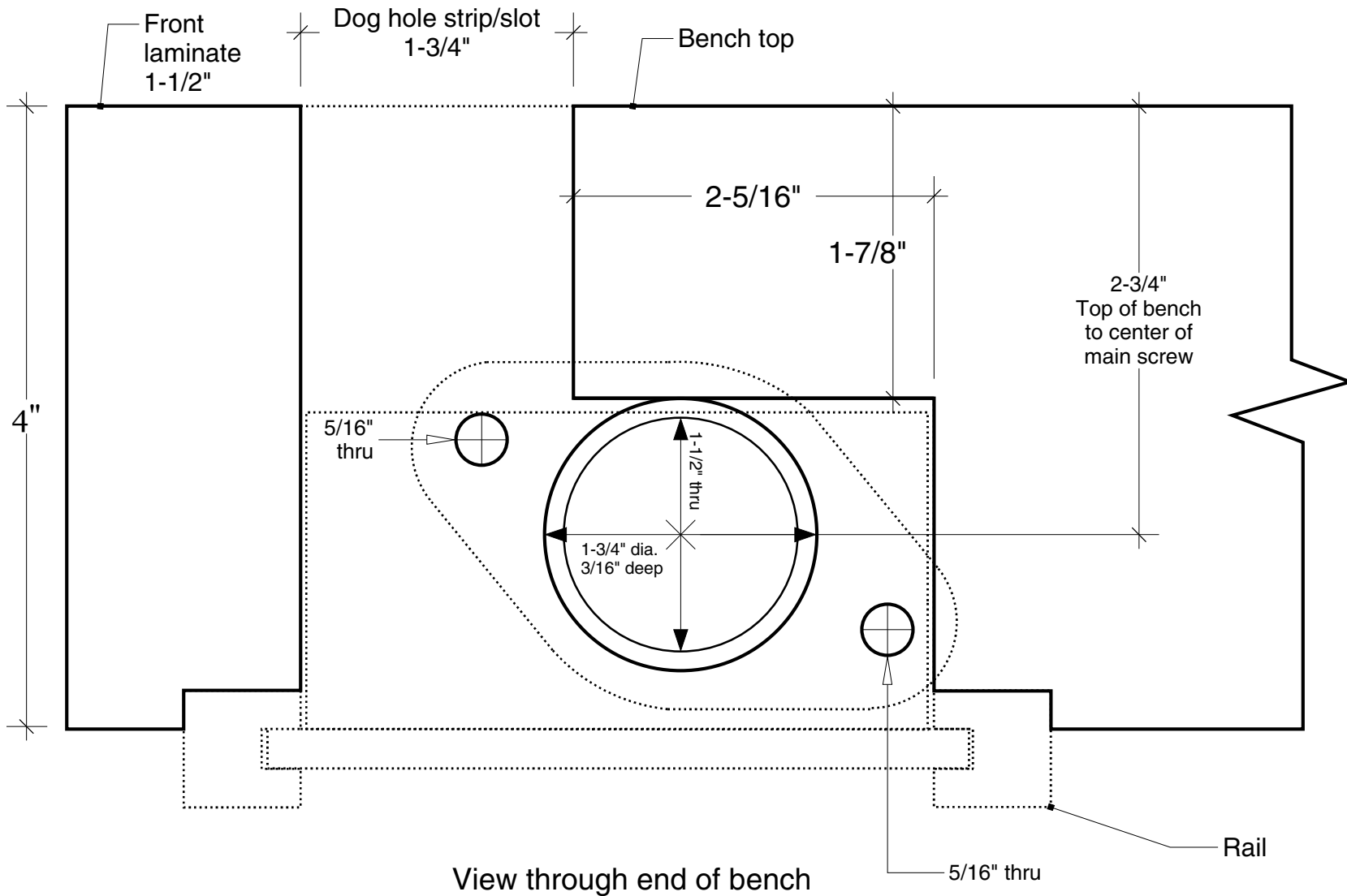

Check scale before using!

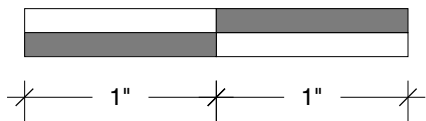

Tail Vise Template
Version Feb 2016



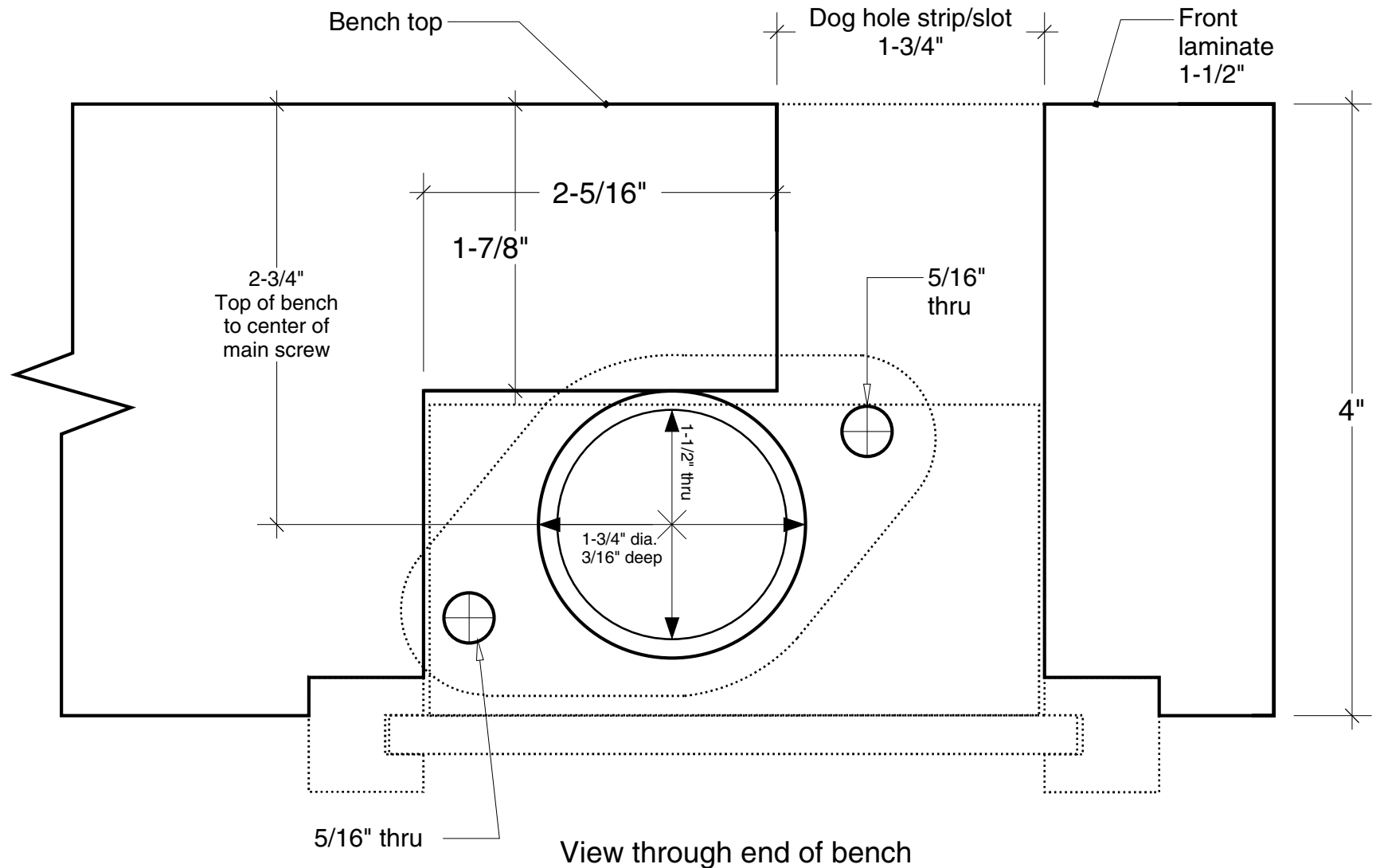

View through end of bench

End cap not shown

Check scale before using!

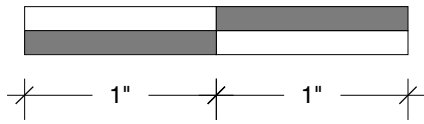

Tail Vise Template - Left Hand Installation

Version Feb 2016



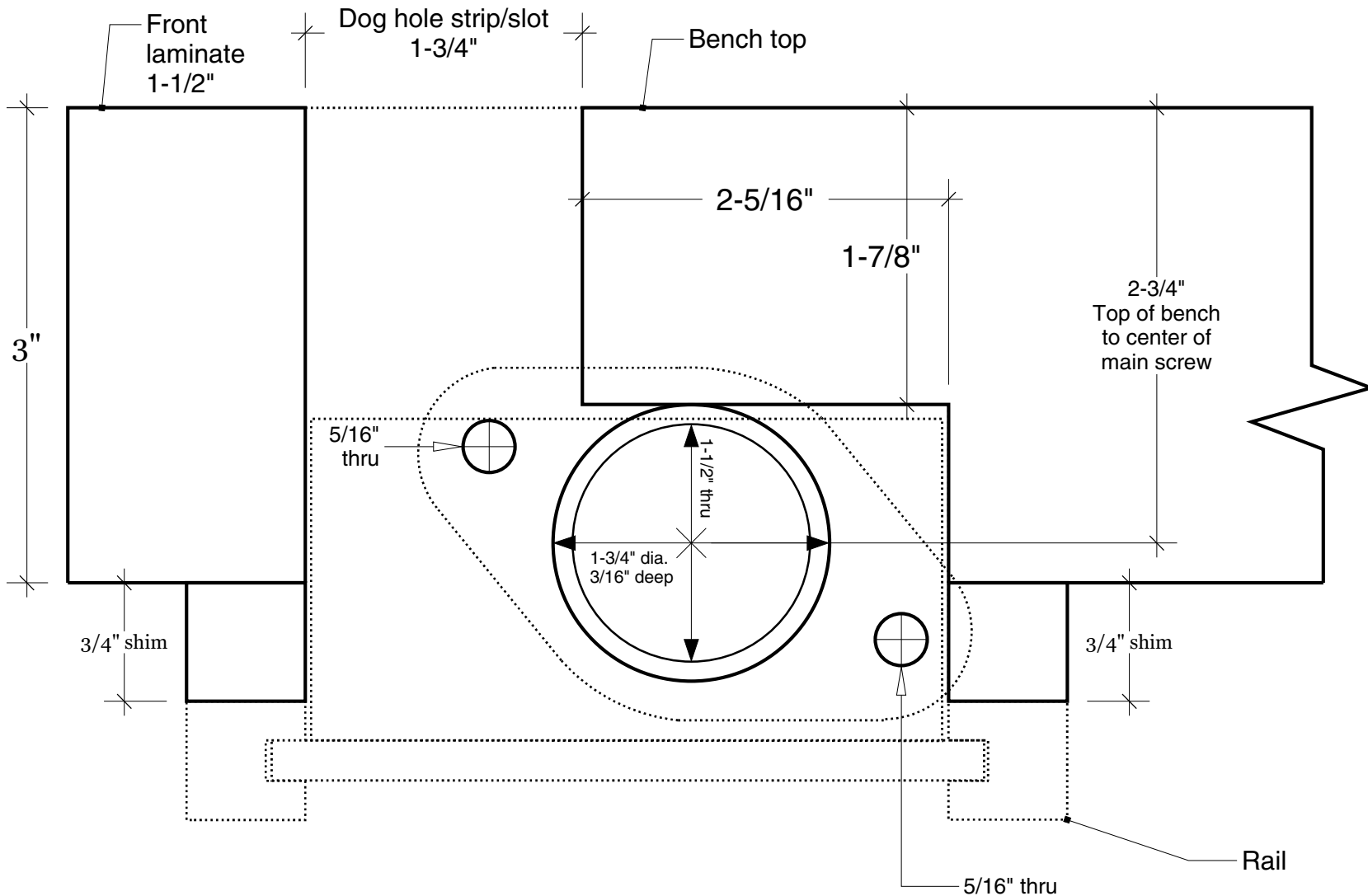

View through end of bench

End cap not shown

Check scale before using!

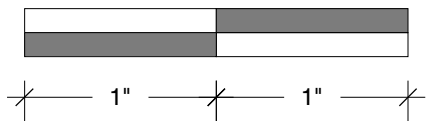

Tail Vise Template for Thin Bench Tops

Version Feb 2016

