

**NEW**

# BESSEY® Auto-Adjust Toggle clamp



Simply better.

Auto-Adjust Toggle Clamp for rapid clamping

**This truly versatile clamp is ideal for short runs, quick set-ups, consolidating part numbers and improving processes.**

**1 Auto-Adjust**

The BESSEY Auto-Adjust Toggle Clamp automatically adjusts to variations in work piece dimensions while maintaining constant clamping force. No more time-consuming manual adjustment of the spindle height to maintain safe and correct clamping force. The removable non-marring plastic cap is included on the 7/8" diameter pads.

**2 Adjustable Clamping Force**

The integrated clamping force adjustment screw can be used to create an actually applied clamping force from 25 to 550 lbs. (max holding capacity 700 lbs.) One BESSEY® Auto-Adjust Toggle Clamp can replace a range of competitive clamps.

**3 Adaptable Base Plate**

The large (2 1/4" by 2 1/2") flanged base is designed for use with 1/4" or M6 fasteners. Mounting holes are sized & spaced for easy mounting and versatility.

**4 Extra large handle**

The large 1" x 2 1/8" handle offers greater user comfort and ease of operation.



**Coming in June 2011**



**NEW** Horizontal toggle clamps

BESSEY® Product #	Opening Inches	Clamping Force Range Pounds	Holding Capacity Pounds	Approx. Weight Pounds	Case qty.
STC-HH50	2	25-550 *	700	0.77	6
STC-HH70	2 3/4	25-550 *	700	0.86	6

\* Variable and dependent on spindle settings, pressure screw setting, force applied etc.

**NEW** Inline toggle clamp

BESSEY® Product #	Opening Inches	Clamping Force Range Pounds	Holding Capacity Pounds	Approx. Weight Pounds	Case qty.
STC-IHH25	1	25-550 *	700	0.86	6

\* Variable and dependent on spindle settings, pressure screw setting, force applied etc.

Product may not be exactly as shown in the pictures above. BESSEY reserves the right to make product changes at their discretion as our on-going goal is to continuously improve product performance.

02-2011-v1-E

**NEW**

# BESSEY® Auto-Adjust Toggle clamp



Auto-Adjust Toggle Clamp for rapid clamping

Simply better.

### STC-HH50 - Horizontal low profile

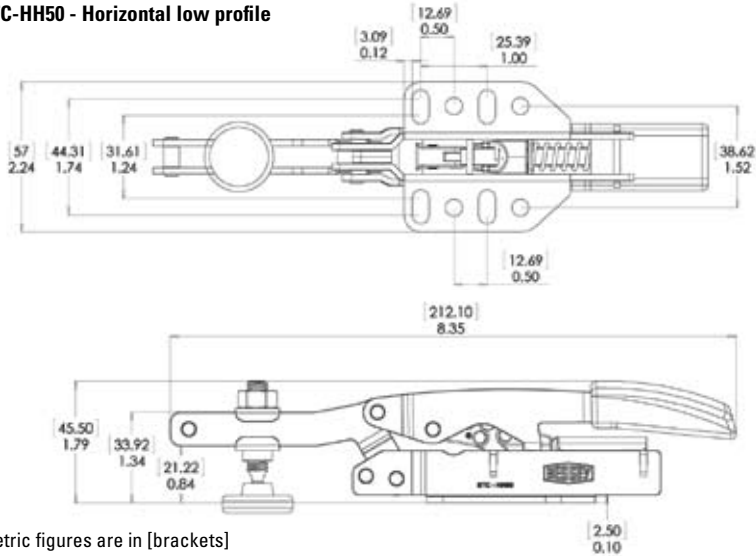

Metric figures are in [brackets]

### STC-HH70 - Horizontal high profile

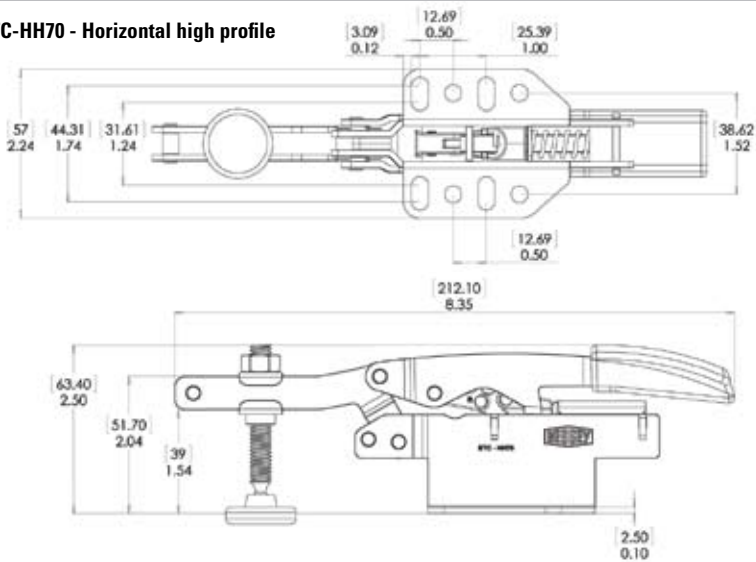

### STC-IHH25 - Inline

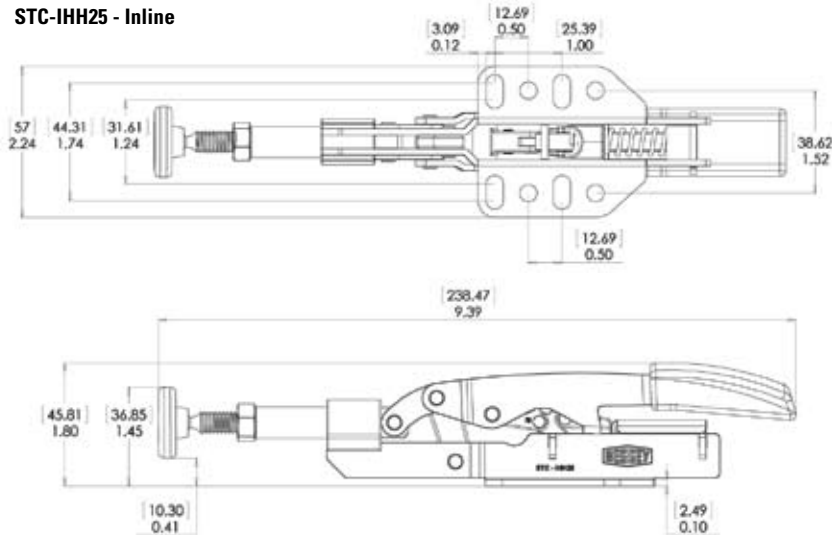

- In the clamped position the handle is horizontal
- Turn the pressure screw counter-clockwise to increase pressure and, clockwise to decrease
- Easy access mounting holes are optimized for 1/4" fasteners (M6)



- Replace a range of competitive clamps with each BESSEY® model
- Spindle thread is M8
- Nut size is .540" (14mm)
- Pad diameter is 7/8"



- High quality construction
- Plunger thread is M8
- Plunger diameter is .465"
- Snap off plastic cap is standard on all models

02-2011-v1-E